

PHOTO SKETCH

OMNI



OMNI LOUISVILLE HOTEL & RESIDENCES

HKS



HOTEL:

600 Keys

- 14 Stories
- 3 Public Levels
 - 11 Guestrooms

Meeting Space:

• Grand Ballroom	21,220sf	
• Jr Ballroom	11,400sf	
• Breakout Meeting	13,600sf	
• <u>Main Prefuction</u>	<u>27,000sf</u>	
Total	73,200sf	

Food & Beverage + Retail:

• Lounge Bar	4,000sf	
• 3-Meal Restaurant	5,000sf	150 Seats
• Bob's Steakhouse	5,900sf	175 Seats
• Coffee Shop	1,800sf	
• Roof Top Bar	3,600sf	
• Retail	4,500sf	
• Speak Easy (Bar + Bowling)		

Amenities:

• Pool Deck + Event Deck	11,000sf	145 Seats
• Event Deck	2,650sf	250 Guests
• Roof Top Bar	3,623sf	
• Fitness	1,850sf	
• Spa	5,600sf	

Parking:

- 6 Levels
- 450 Cars

2

RESIDENTIAL:

225 Units

- 14 Stories Guestrooms

Residential Mix:

- Studio 5%
- 1-Bedroom 55%
- 1-Bedroom Den 7%
- 2-Bedroom 32%

Amenities:

- Pool Deck
- Social Living Room
- Business Center
- Community Kitchen

Parking:

- 6 Levels 330 Cars

3

URBAN MARKET:

20,000 sf

Parking:

- At Grade Parking 55 Cars (40 Req.)
 - 55 Urban Market
 - 6 Residential Visitor 6 Cars

4

PARKING:

6 Stories Parking: +-850 Cars (820 Req.)

- **Grade**
- **5 Above**

Parking:

- Level 1
- Level 2
- Level 3
- Level 4
- Level 5
- Level 6

Hotel

63 Cars
91 Cars
91 Cars
93 Cars
112 Cars

Res.

6 Cars
59 Cars
91 Cars
91 Cars

Market

55 Cars

450 Cars

338 Cars

55 Cars

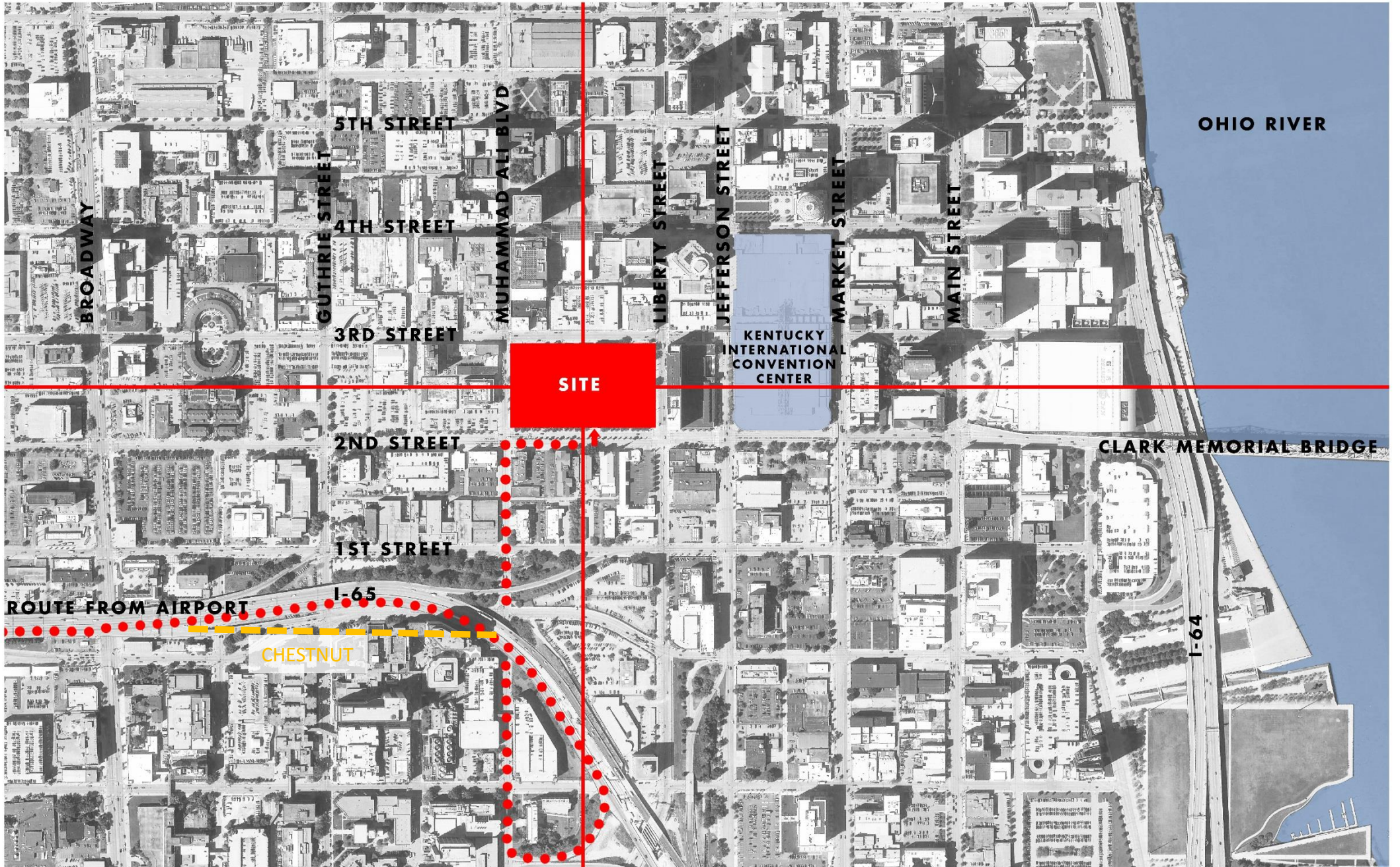

LOUISVILLE... A PLACE RICH IN HISTORY AND TRADITION...

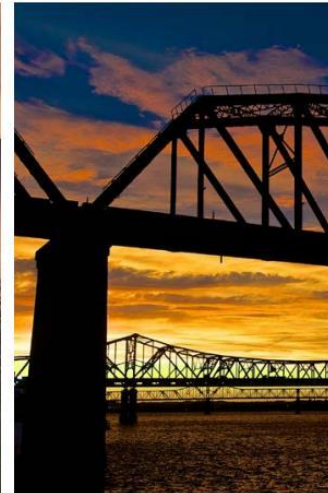



CROSSROADS

HKS



U R B A N C O N T R A S T

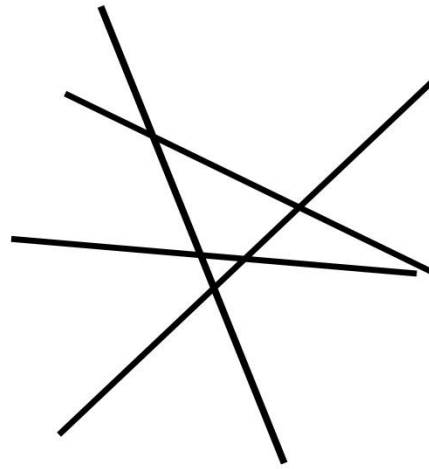

CROSSROADS OF
PAST
PRESENT
FUTURE

“CROSSROADS”

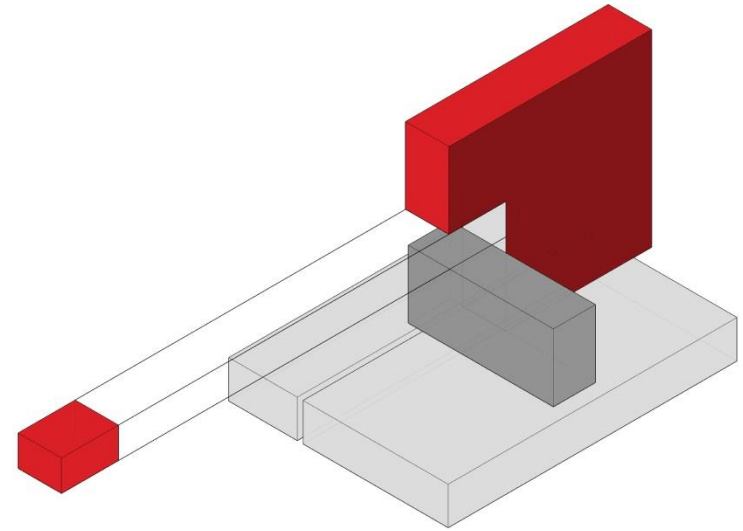

EXPRESSED INTERSECTION
THROUGH SUBTRACTION
OF FORM

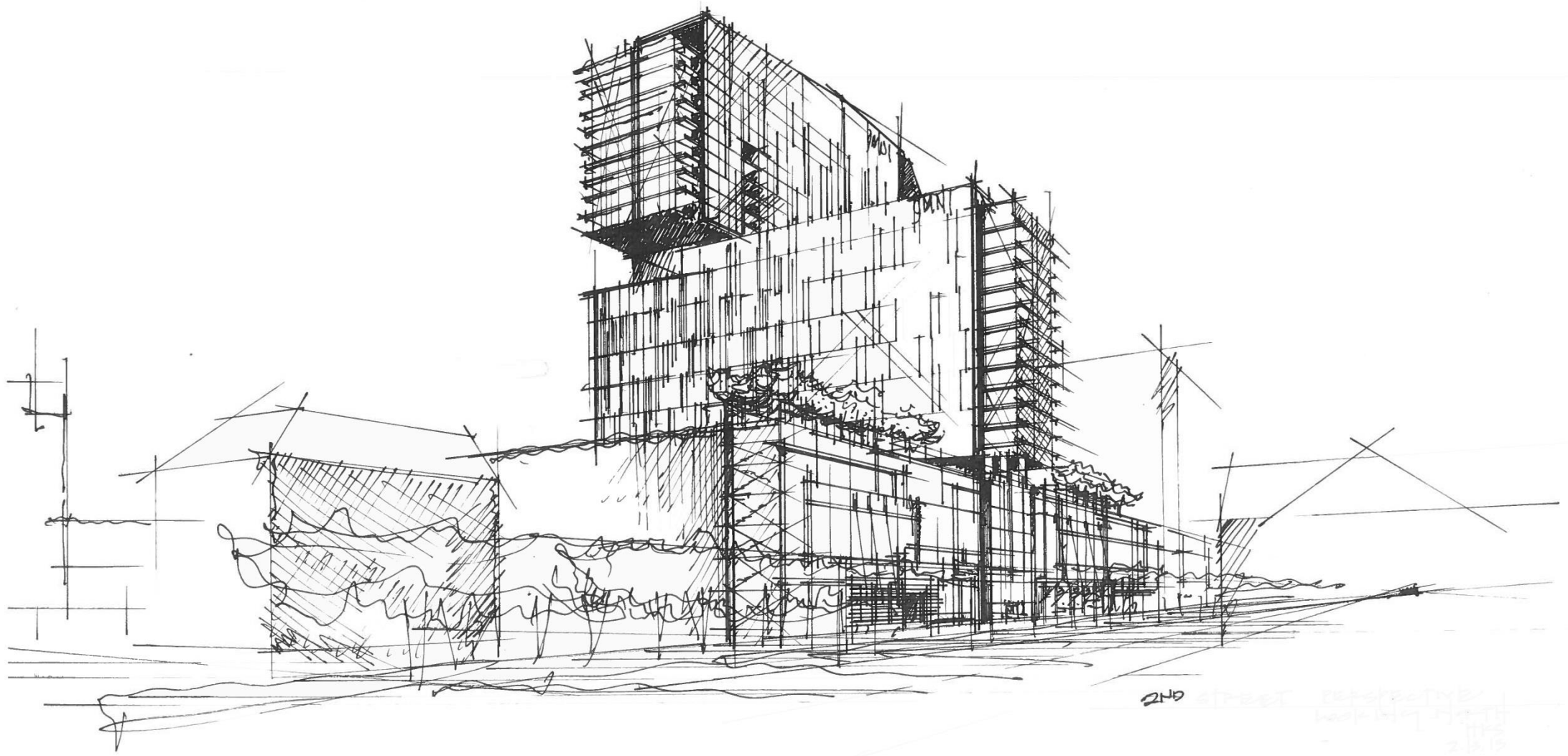



OMNI HOTEL
OMNI HOTEL

OMNI HOTEL
& RESIDENCES

HKS



“SPIRIT”

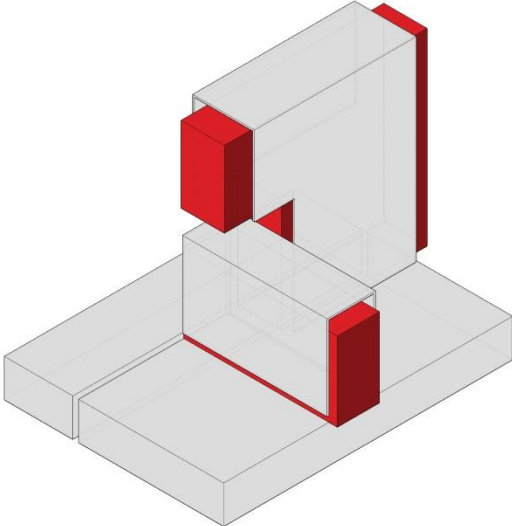

INTERIOR EXPRESSED
EXTERNALLY



OMNI HOTEL

OMNI HOTEL

HKS





Activate Street Life



Sense of Neighborhood







“COMMUNITY”

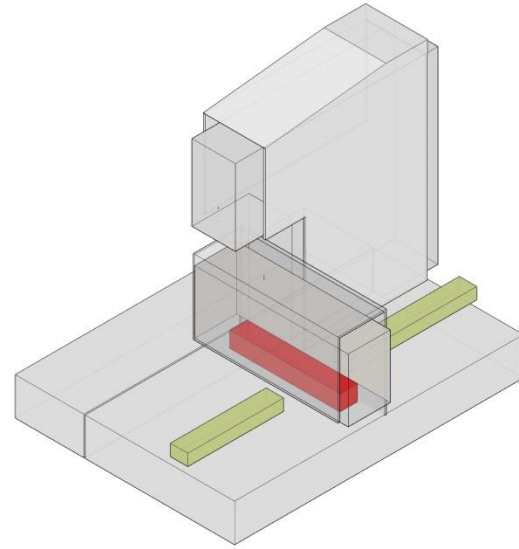

CELEBRATED THROUGH ICONIC SPACE

COMMUNITY & CIVIC PRIDE



REPURPOSE SPACE







THANK YOU!

HKS